

## UNION PARA EXTREMOS LISOS

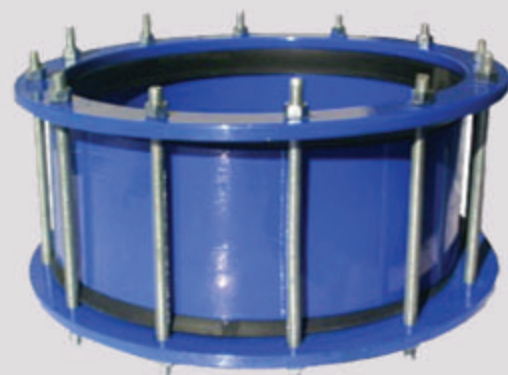

### MATERIALES Y REVESTIMIENTO

	Material	Revestimiento
Bridas	Acero A-36	Resina Epoxy
Hilos	Acero SAE 1020	Dicromatado
Sello	Caucho NR SBR	
Cuerpo	Acero A-36	Resina Epoxy

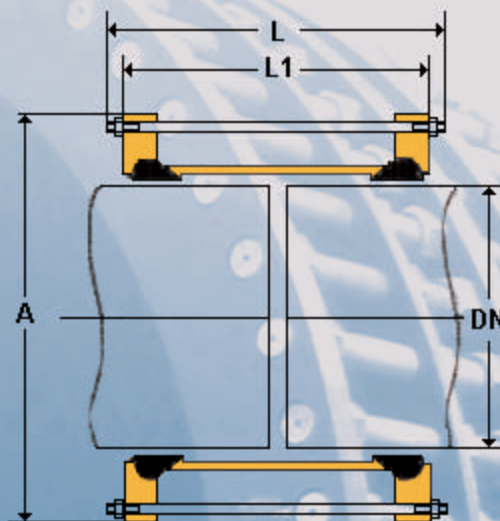

DN	PVC DN	DUCTIL DN	ROCALIT AW-20 DN	A	L	L1	HILOS
200	200	222	238	348	330	170	6
250	250	274	290	410	330	170	8
300	315	326	346	466	330	170	8
350	355	378	404	524	330	170	8
400	400	429	462	582	330	240	10
450	450	480	520	640	330	240	10
500	500	532	574	694	330	240	12
600		635	676	796	330	250	14
700		738	788	908	330	250	14
800		842	904	1024	330	250	16
900		945	1012	1132	500	325	18
1.000		1048	1124	1244	500	325	18